



www.smoothline.com

**Highest Quality Worldwide
Sports Car Hardtops**

2562 Riddle Run Road Tarentum, PA. 15084

Phone 724.274.6002
Fax - 724.274.6121

Installation Instructions

Triumph TR3, TR3A, TR3B

You have just purchased the finest Hardtop available on the market today. Skilled craftsmen using the highest quality materials and modern technology have manufactured this product. By following these simple instructions you will have many years of enjoyment and the top will last as long as your car.

The following tips will be helpful if you are qualified to do it yourself. If not, we recommend that your Hardtop be installed and finished by a professional body shop.

A point to remember, automobiles are mass-produced and built with certain tolerance. Sometimes these tolerances are quite large. No two are alike. A body man is a skilled tradesman; a skill that is not learned overnight. A “well fitting” automobile is a series of adjustments and compromises.

DO NOT PAINT until after initial installation. After this initial installation procedure on/off will be as easy as placing the convertible top up/down position.

The hardtop is molded with a high degree of inward camber in order to provide a tighter fit at the critical points on the rear deck (when completely tightened down). As such, the top will not appear to fit correctly when first placed on the car. However, as it is tightened down the rear flange will fit properly. The fiberglass will tend to conform to the shape of the car after the first fitting but will still retain some of the spring to assure a good seal. Subsequent installations will be much easier than the initial fitting.

A. Prior to placing the top on the car:

1. Fold top cloth into the normal top down position.
2. Clean top of windshield frame and rear deck area.
3. Lubricate the bottom of the deck rubber of the hardtop with a silicone lubricant or Vaseline.
4. Place the supplied aluminum adaptor plates (one per side) on the existing convertible top frame at the mounting pivot point. Use the flathead pivot screw to attach the adaptor plate in a vertical position with the large hole up.
5. On the windshield frame, drill a 5/16 "hole approximately 1" below the top of the frame through the windshield post flange (both sides). These are the attachment points for the front "J" hooks of the hardtop.(refer to Fig 2)

B. Place hardtop on the car:

1. Make sure that the side window moldings are not pinched between the top and the windshield frame (these will be trimmed later). The top should fit snugly on the windshield frame.
2. Attach the rear hooks into the adaptor plates.
3. Install the front "J" hooks into the drilled holes on the windshield post flange. Hooks should be installed with the "J" facing the outside of the car. The hooks may need to be bent slightly to fit properly. Once installed, you may want to remove the excess part of the "J" hook which protrudes through the flange (mark the portion to be removed and take the bolt off to file or grind).
4. Once the top is properly positioned, begin to tighten the latches by hand.
5. Trim the excess window rubber with scissors or a knife (see Fig. 1)
6. Finish tightening all latches by hand until top is firmly seated and lock all latches with locknuts.

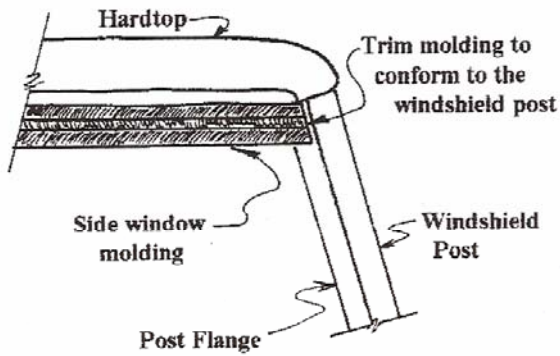

Fig. 1: Trimming Side Window Moldings

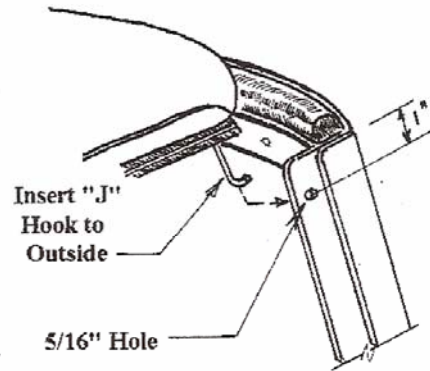

Fig. 2: Front Fastener

C. Maintenance of the top:

1. Side window rubber molding may be lubricated with a silicone base wax of Vaseline for easy winding of the windows. Similar lubrication may be used on the deck rubber seal if squeaking occurs.
2. If painted, keep surface waxed to preserve the gloss finish. On vinyl tops, clean periodically with a vinyl cleaner and coat with a vinyl top sealer.
3. The rear window is Plexiglas and caution should be exercised to prevent scratching. Clean with mild soap and sponge or soft cloth. Dry with a chamois skin – keep dirty rags away from the window. A plastic wax such as “Mirror Glaze” can be used to wax the window.

If the top is to be painted : Mask off rear window with cellophane or a non-porous material to prevent thinner fumes from attacking the Plexiglas.

The factory primed surface must be top coated before being exposed to the weather. Failure to topcoat over the prime coat can cause blisters or delamination and will void the warranty

Warranty: All Smooth Line Hardtops are warranted to be free from defects in material or workmanship and are warranted for one (1) year from date of purchase. Smooth Line will, at its discretion, repair or replace at its factory, without cost, any part that fails in service, upon our inspection, within the warranty period. The warranty does not cover freight, labor, failure of related components or failure resulting from alteration, misuse, accident damage, faulty installation, color coating, or faulty repair. For warranty service for a Hardtop purchased from a distributor you must make all arrangements through that distributor. If purchased directly from Smooth Line contact Smooth Line sales department. Warranty for all components must be supported by the proper registration documentation including the original shipping invoice. At no time are Smooth Line Hardtops returnable for credit or refund for any reason.

Returned Goods: Written authorization must be obtained from Smooth Line and the distributor before merchandise may be returned for warranty service. All merchandise must be properly packaged in non damaged condition. An itemized packing slip, showing invoice number and date, with full explanation of reason for return must be included. All returns must be sent freight prepaid. All costs relative to a return are not reimbursable.

Freight Damage: Smooth Line products are carefully packaged by professionals. Delivery in good condition is the responsibility of the carrier. All shipments are insured. Upon receiving your merchandise, while in the presents of the delivery driver, before signing, carefully inspect carton for damage or rough handling. If apparent, open package and inspect merchandise. If damaged, refuse shipment, have driver note damaged on bill of lading. Call Smooth Line after driver leaves with the shipment.

The above terms and conditions pertain to all orders and will be strictly applied. Please do not ask for exceptions.

WARNING

This product is designed to enhance the appearance of the vehicle and to shield the occupants from ordinary weather conditions. Do not rely in any way on the components of this product to contain occupants within the vehicle, or to protect against injury or death in the event of an accident. This product will not protect the occupants from falling objects.

WEAR SEAT BELTS AT ALL TIMES.